

Sep.1.2024 Copyright 2024 HIROSE ELECTRIC CO., LTD. All Rights Reserved.  
In case of consideration for using Automotive equipment / device which demand high reliability, kindly contact our sales window correspondents.

CABLE ASSEMBLY TOOL

FOR SOLDERING : HRM-200/SO-MD

FOR PRESS FITTING : HRM-200-PJ4BN/CV-MD

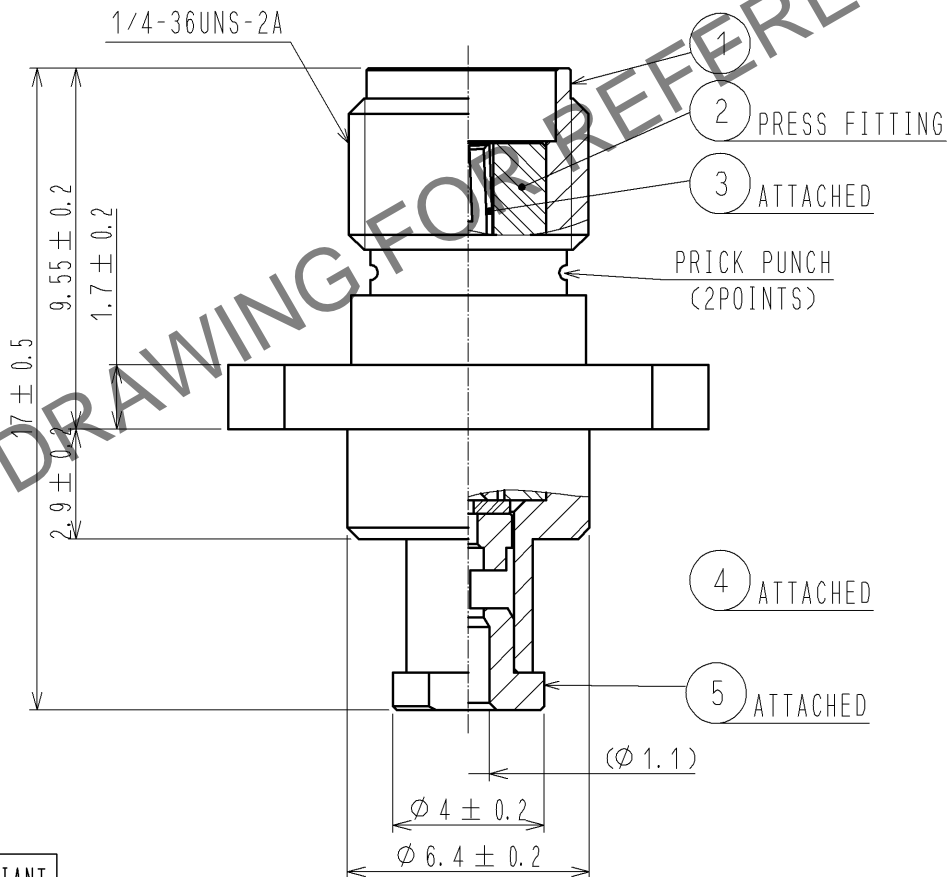
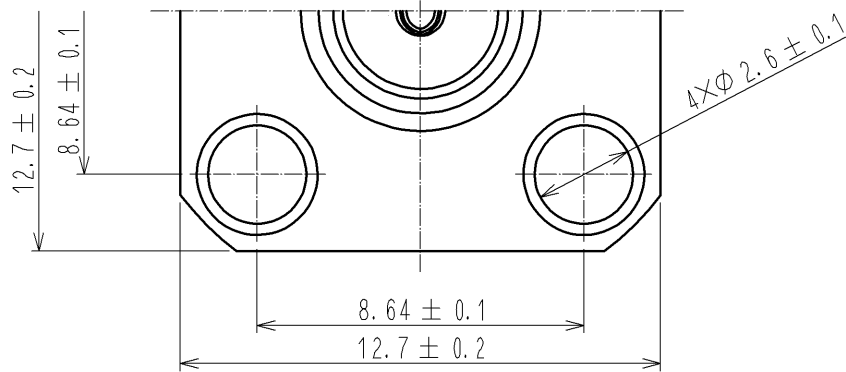

RoHS COMPLIANT

3	BERYLLIUM COPPER	GOLD PLATING					
2	PTFE		5	BRASS	GOLD PLATING		
1	BRASS	NICKEL PLATING	4	PTFE			
NO.	MATERIAL	FINISH .	REMARKS	NO.	MATERIAL	FINISH .	REMARKS

UNITS mm		SCALE 5 : 1	COUNT 	DESCRIPTION OF REVISIONS	DESIGNED	CHECKED	DATE
<b>HRS</b> HIROSE ELECTRIC CO., LTD.		APPROVED : TS. NOBE	11. 09. 24	DRAWING NO.	EDC4-305107-40		
		CHECKED : NK. NINOMIYA	11. 09. 24	PART NO.	HRM-200-040PJ4BN<40>		
		DESIGNED : YI. FUNADA	11. 09. 24	CODE NO.	CL323-0795-7-40		1/1
		DRAWN : YI. FUNADA	11. 09. 24				